

Table of Contents

INTRODUCTION	1
INSTALLATION.....	1
CHAMBER OPERATING RANGES.....	11
CONTROL SYSTEM.....	13
LT-41 DEFROST SYSTEM	14
REMOTE ALARM CONTACTS (IF APPLICABLE)	15
AIR BLOCKS (IF APPLICABLE)	16
CHAMBER LIGHTING	17
LIGHTING SPECIFICATIONS.....	17
CHAMBER HUMIDITY (IF APPLICABLE)	18
MAINTENANCE.....	19
TEMPERATURE CONVERSION CHART	27
SERVICE INFORMATION - TEMPERATURE SYSTEM	28
SERVICE INFORMATION – FLUORESCENT LIGHTING (IF APPLICABLE)	29
SERVICE INFORMATION - HUMIDITY SYSTEM (IF APPLICABLE)	30
SERVICE INFORMATION - GENERAL	31
PARTIAL PARTS LIST	31

Introduction

This manual is designed to aid and instruct the user in the installation, operation and service of the Series 41 controlled environment chamber, referred to as simply “chamber” or “unit” in this manual. The contents of the manual will provide a reference for the programming of the chamber to meet the basic requirements for simulated environmental studies.

The user is reminded that Percival Scientific, Inc. is available to assist the technician (or researcher) in setting up programs for specific projects. We can be reached via telephone by calling either 1-800-695-2743 or 515-465-9363, or by sending e-mail to service@percival-scientific.com.

Percival Scientific continuously studies the design of its controlled environment equipment in order to offer the customer the best equipment available for their lab needs. As a consequence, changes in the design and operation of equipment occasionally occur without publication. Please feel free to contact Percival Scientific directly for product updates.

Installation

Locate the chamber

The location of this chamber is extremely important in order to achieve and maintain optimum performance from the unit throughout its designed operating range(s). The initial factor for determining the proper location is the service facilities. Refer to the chamber’s serial tag and/or the Basic Cabinet Electrical Diagram for electrical service requirements and locate the unit near the proper facilities.

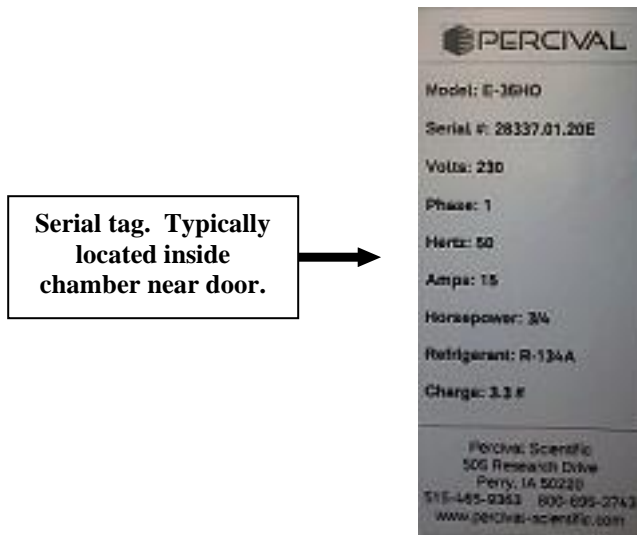

The area in which the chamber is to be located should be as level as possible. Adjustable levelers may have been provided to allow for compensation for unevenness in the floor area. If not, wood or metal shims may be used to level the unit.

Please note: the casters provided on the chamber are intended only for moving the **EMPTY** chamber short distances on indoor, finished surfaces for installation or relocation. Do not attempt to move the chamber when it contains experiments, samples or other materials.

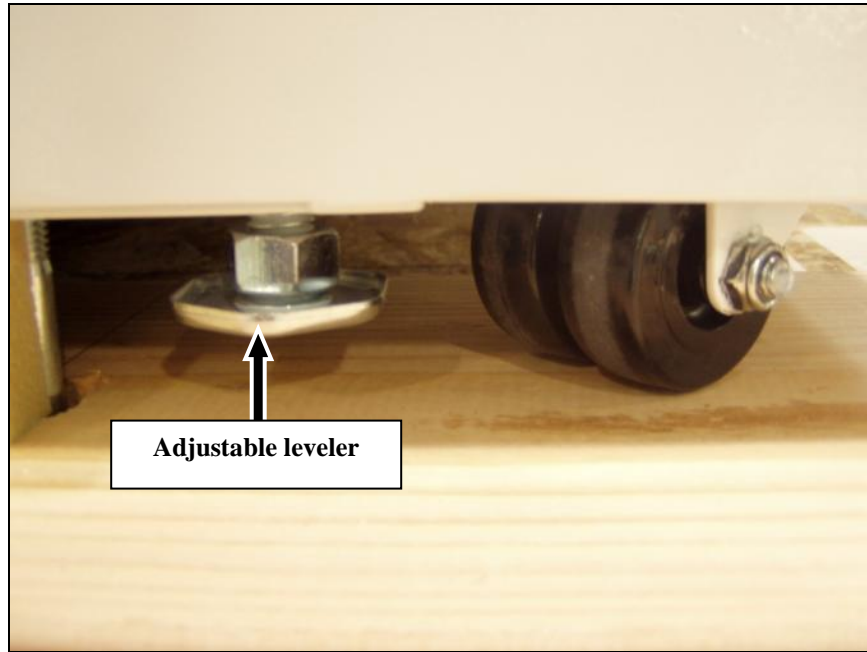

Care should be taken to locate this chamber in an area that allows suitable ventilation and circulation. To facilitate the removal of heat generated by the unit, allow a minimum six-inch space along the right-hand side of the chamber to properly ventilate air-cooled condensing units.

To maintain maximum efficiency from this unit, it is suggested that the ambient be ideally 75°F (24°C) and 50% relative humidity. High ambient temperatures may measurably affect the unit's performance.

Uncrate the chamber

If the chamber is crated, remove the top and sides of the crate and all wrappings. If it is not crated, remove the shrink-wrap surrounding the unit. Carefully inspect these shipping materials (crate or shrink-wrap) to ensure no loose parts were fastened to them that may accidentally be discarded. Some loose parts may have been shipped separately. Verify the proper number of pieces were received as per the Bill of Lading.

Remove loose parts and shipping materials

Remove all loose parts and shipping materials from inside the chamber. Unwrap all loose parts that are to be installed in or on the unit.

Remove chamber from skid

From the underside of the skid, remove the four bolts holding the chamber to the skid and carefully slide the unit off the skid.

⚠ WARNING

The chamber is top heavy.

Install condensate pan or connect tubing to drain line(s)

If a condensate pan was shipped with the chamber, place it under the chamber beneath the drain that exits in the center of the floor. The pan collects all water that is drained from the chamber. The pan should be checked periodically and emptied when full to prevent water from overflowing onto the floor.

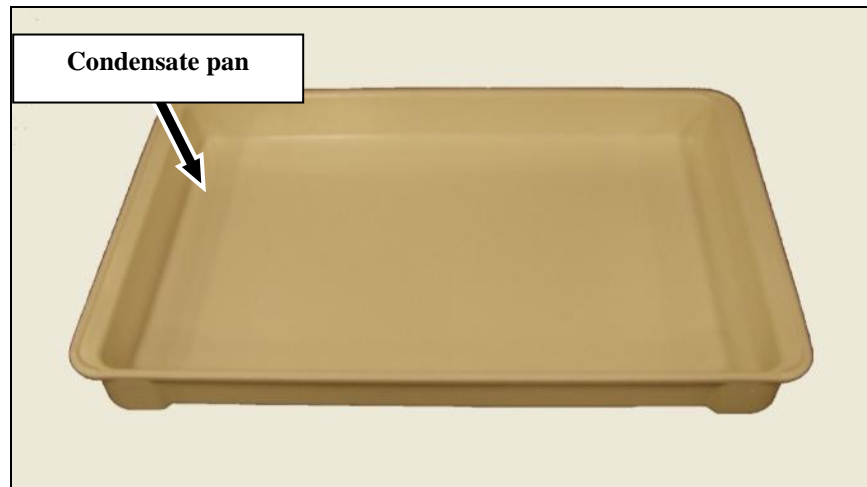

If a condensate pan is not provided, then a floor drain line exists. The floor drain line is plastic tubing that directs condensed water from the chamber. The tubing terminates at the bottom rear of the chamber. Connect tubing to this line and direct to an appropriate drain.

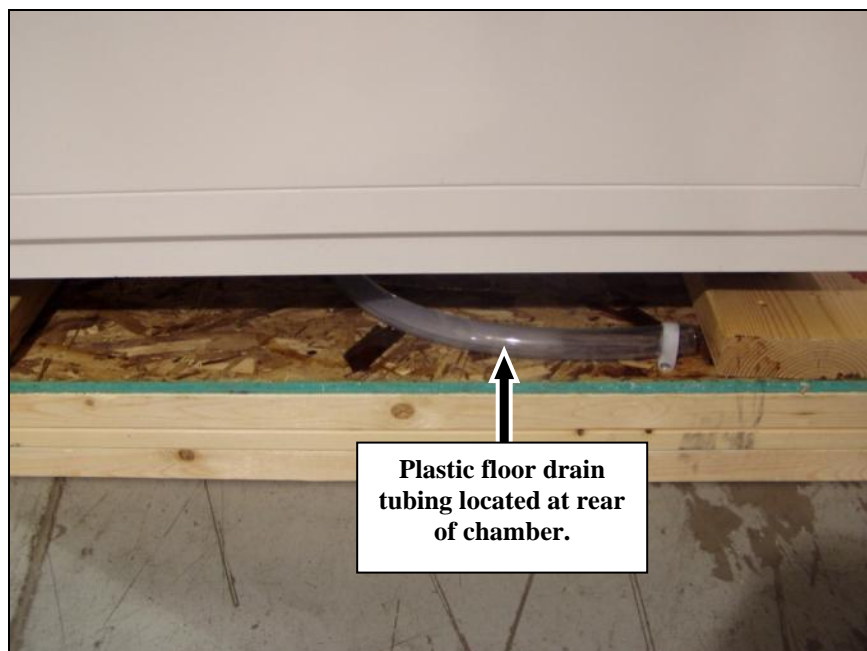

Make water-cooled condensing unit connections (if applicable)

If a water-cooled condensing unit is utilized, make water inlet and outlet connections to the unit. If assistance is required in making these connections, contact your service representative. If no service representative is available, contact Percival Scientific for instructions on making these connections.

Pan-type humidifier (if applicable)

- AL-41, AR-41, CU-41, GR-41L, GR-41VL, E-41L, E-41HO, E-41VL, LED-41L

If equipped with a pan-type humidifier, the humidifier was pre-installed at the factory and is located behind the unit cooler.
- LT-41VL

If equipped with a pan-type humidifier, place the humidifier on the floor so that the float valve connection on the humidifier is aligned with the water supply line located on the inside of the chamber. Connect the water supply line to the humidifier. Locate the plug(s) on the heater(s) supplied and plug into the receptacle(s) labeled “Humidifier/Heater”.

Make humidifier water source connection (if applicable)

Humidifier water requirements	–	pH:	7.0 ± 0.5
		Filtration:	< 2 microns
		Resistivity:	0.5 – 5.0 MΩ

Note: It is strongly recommended that de-ionized, distilled or de-mineralized water (water that has been treated to remove nearly all minerals and sodium that occur naturally in water) be used for humidification. If using mineralized water, expect chemical and mineral buildups throughout chamber requiring frequent and thorough cleaning to prevent system performance degradation and equipment damage. It is recommended that de-ionized water be used which can be obtained by the use of a water softener.

When a humidifier is supplied, the chamber is equipped with a hand valve and water line which terminates with either a ½ inch MPT fitting or a compression style fitting. The humidifier water supply fitting is located on the outside side or rear wall of the chamber.

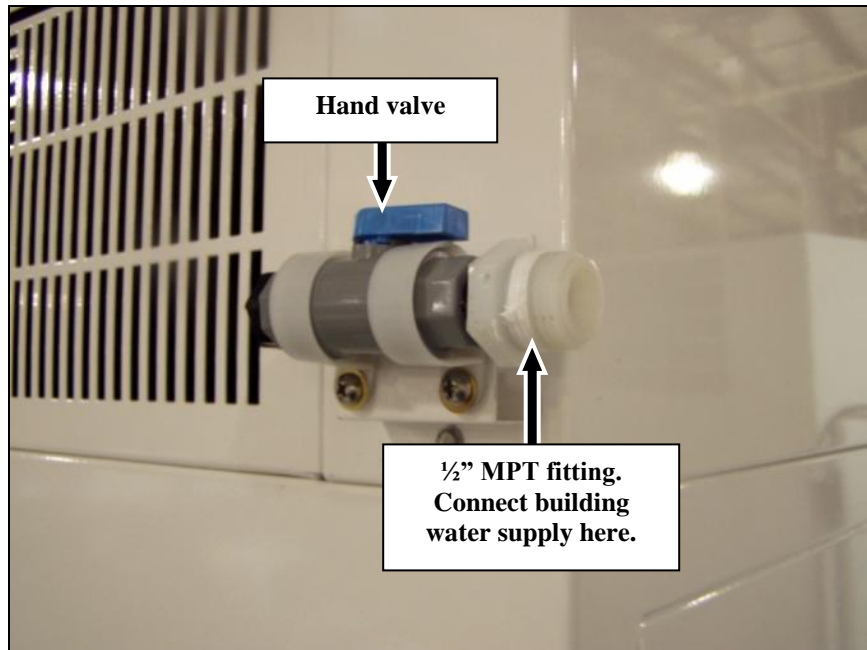

If a ½ MPT fitting is supplied, your water supply (see note above) should be connected to this line with a ½ inch FPT fitting for proper compatibility.

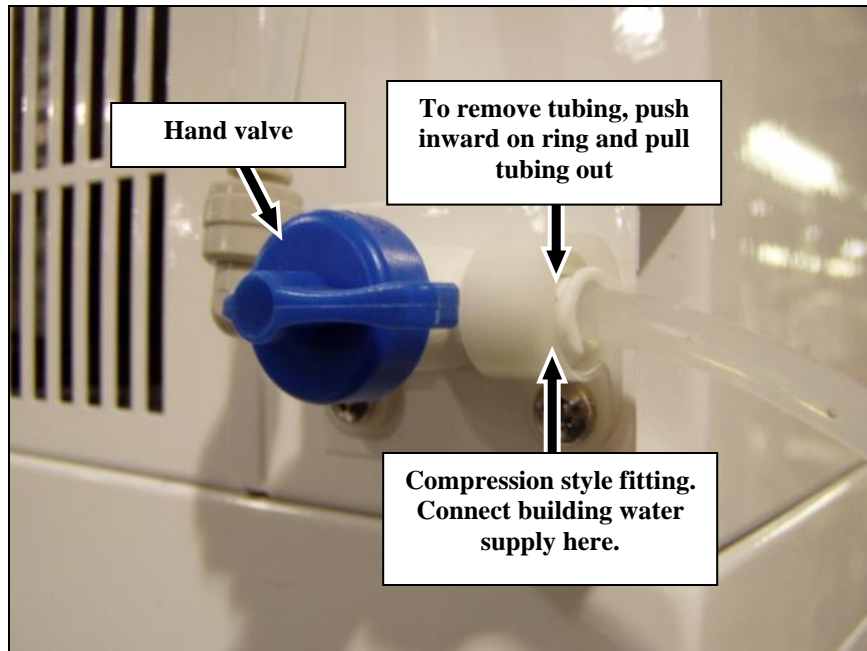

If a compression style fitting is provided, either connect $\frac{1}{4}$ " tubing directly to the fitting or install the provided $\frac{1}{2}$ MPT adapter. To directly install $\frac{1}{4}$ " tubing simply insert the tubing into the fitting as far as it will go (see photo above). To remove the tubing, push inward on the ring surrounding the tubing and pull the tubing out of the fitting.

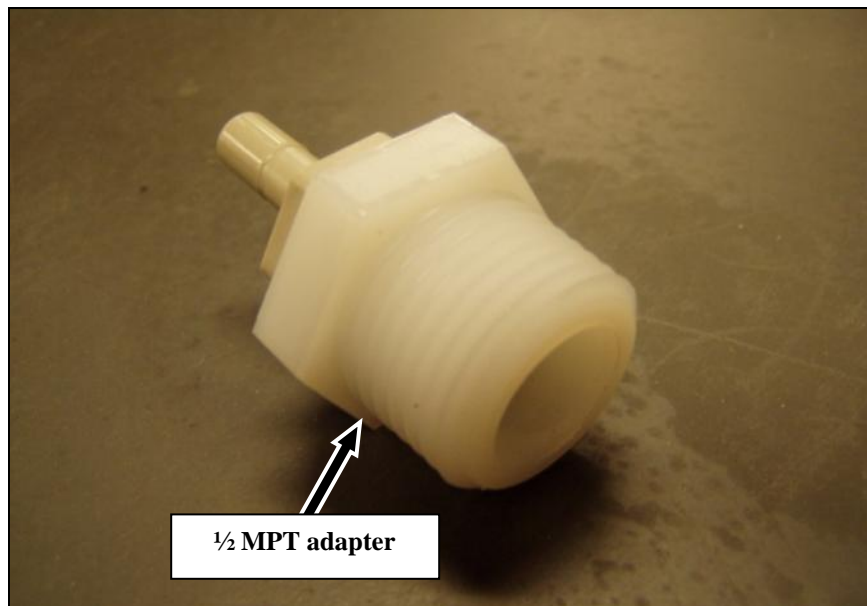

(Optional) $\frac{1}{2}$ MPT adapter. Insert into compression fitting and connect water supply with $\frac{1}{2}$ FPT fitting

Once the proper water supply connections have been made, open the water line hand valve and turn the water supply source on. The humidifier automatically adjusts for the proper water level.

⚠ WARNING

Under normal temperature operating conditions, to prevent damage to humidifier, always ensure that the water supply source is on and the water line shut off valve is in the open position. Operating the humidifier without water may damage the humidifier.

Install SciWhite® LED tiles (standard)

If your chamber includes standard SciWhite® LED tiles, the fixtures may need to be installed.

- AL-41, AR-41,
E-41L, E-41HO,
LED-41L

Securely fasten the supplied pilaster clips into the pilasters located inside the chamber at the desired elevation for each fixture.

A pair of pliers or similar tool may be required to install the clips on the pilasters. Once the clips have been securely installed, install the fixture on the clips.

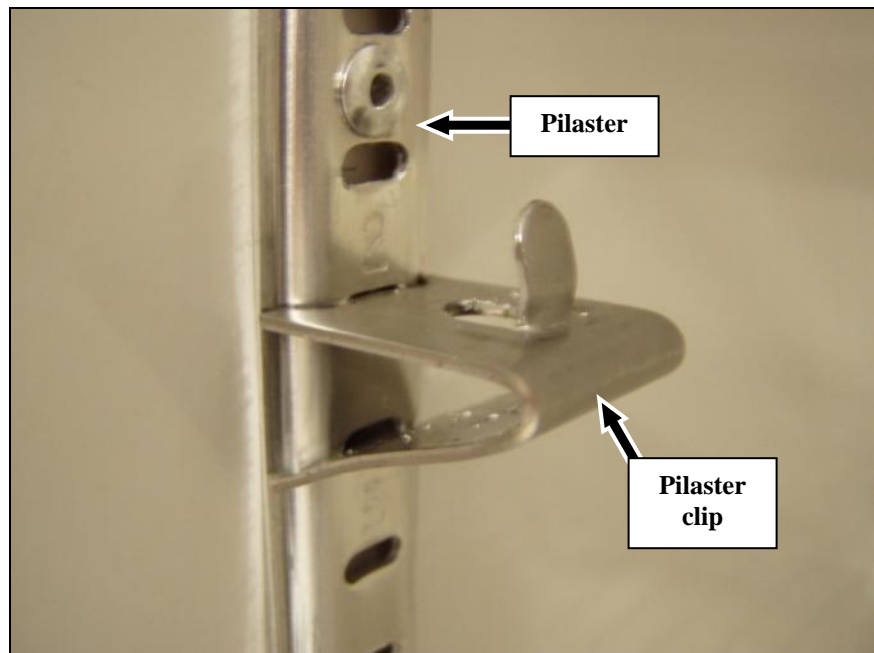

- CU-41L Slide the SciWhite® fixtures into the provided channels
- E-41VL, LT-41VL Standard vertical SciWhite® tiles pre-installed

Before starting the chamber, be sure that all the 3 pin plugs are securely inserted to the correct outlet.

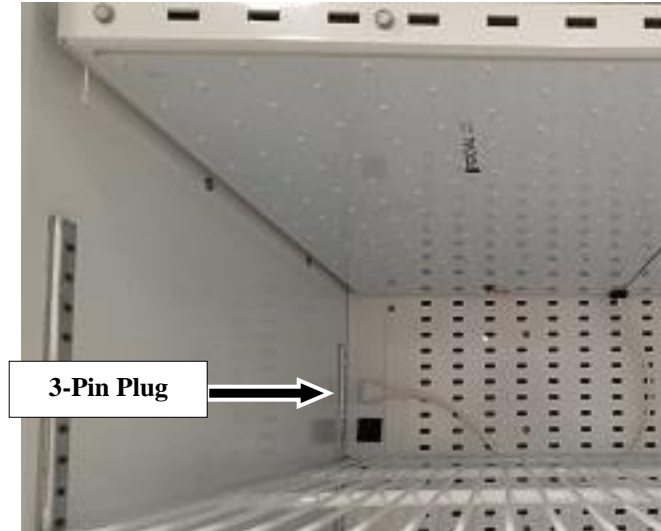

Install fluorescent and / or incandescent lamps (if applicable)

If your chamber includes a fluorescent / incandescent lighting option, locate and install all lamps that were shipped as loose equipment. Refer to the chamber lighting diagram(s) provided in the *Associated Diagrams, Schematics and Miscellaneous Information* section of this manual for lamp style and wattage requirements.

Note! Never plug in lights or light fixtures unless the chamber power is off.

- AL-41 (optional),
AR-41 (optional),
CU-41 (optional),
E-41L (optional)
To install a fluorescent lamp, place lamp end caps (supplied) on each end of a lamp and slide the lamp with caps over the lamp holders until it snaps into place *. Do not twist the lamps or they may break. Repeat this process with any additional lamps.
- GR-41L (standard),
GR-41VL (standard),
E-41VL (optional),
LT-41VL (optional)
The lamps have been pre-installed. Refer to the maintenance section for information on changing lamps.

- E-41HO (optional)

The lamp fixture utilizes compact fluorescent bulbs and incandescent bulbs.

To install a compact fluorescent bulb when metal support clips are supplied, insert the bulb into the lamp holder and push upward on the opposite end of the bulb near the clip until the clip supports the bulb.

To install a compact fluorescent bulb when plastic support clips are supplied, insert the bulb into the end support clip and then push lamp directly into the lamp holder. Next, secure the lamp by closing the clip.

*** - Note: For CU-41, AL-41, AR-41, GR-41 and E-41 models, the lamp holder caps must be securely installed against the lamp holders! Please reference the drawings below:**

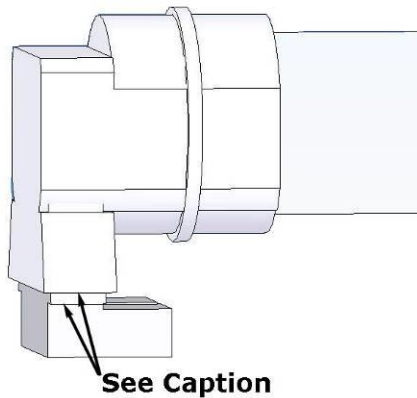

Incorrect installation – gap exists between lamp holder cap and lamp holder

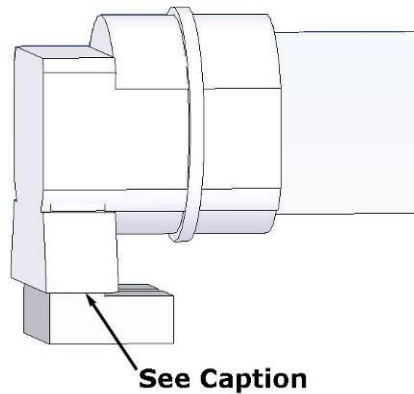

Correct installation – no gap exists

Install shelving

- CU-41, GR-41L

Unpack the shelves and install them in the shelf slide brackets provided.

Repeat this process with any additional shelves.

- AL-41, AR-41,
E-41L, GR-41VL,
E-41HO, E-41VL
LT-41VL

Securely fasten the supplied pilaster clips into the pilasters located inside the chamber at the desired elevation for each shelf.

A pair of pliers or similar tool may be required to install the clips on the pilasters. Once the clips have been securely installed, install the shelving on the clips.

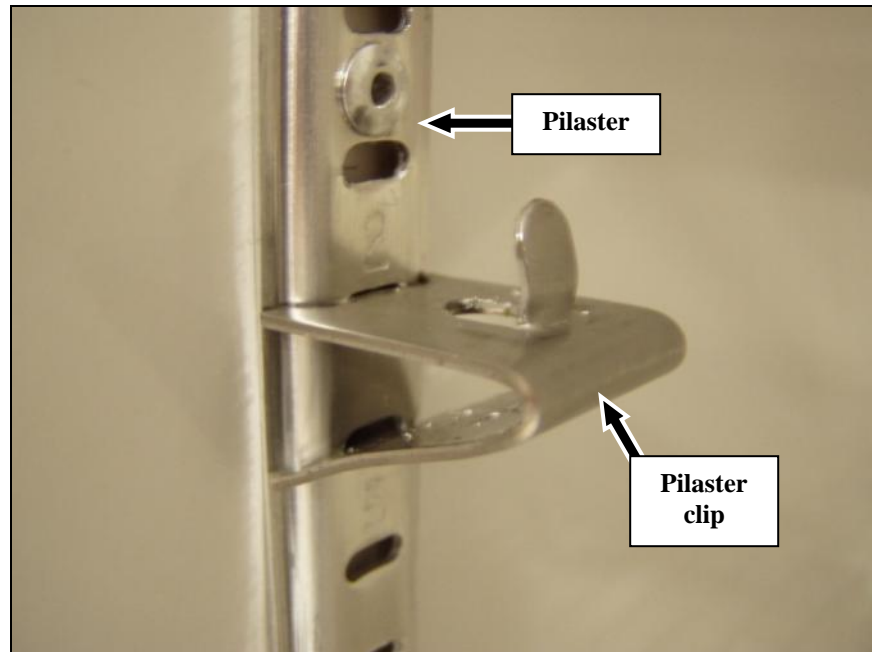

Make chamber electrical connection

Before making the chamber electrical connection, check the line for proper size and voltage. Refer to the serial plate or Basic Cabinet Electrical Diagram for unit voltage and amperage requirements. For example, if a 120VAC, 15-amp connection is required, ensure that the source power and service receptacle is 120VAC and meets or exceeds 15A. If your unit is equipped with (2) power cords, each cord must have a dedicated circuit (2 separate circuits) even if the total amperage is under the rated amps of the circuit. Consult an electrician if unsure. The line voltage generally should not be $\pm 10\%$ outside of the voltage required for your chamber. If the voltage is outside of this range, damage to the subcomponents of the chamber can occur.

The National Electric Code states that a circuit cannot be loaded more than 80% of the circuit capacity for continuous load applications. This means for a 20-amp circuit, you can only have a maximum of 16 amps plugged into that circuit. A maximum of 12 amps for a 15-amp circuit.

For models provided with hermetic (welded) condensing units with extended voltage motors (e.g. 208/230V), it is recommended that the voltage be within the range of -5 % to +10 %. Refer to the condensing unit item listing on the Basic Cabinet Electrical Diagram for condensing unit voltage requirements.

Once the line voltage and size has been verified, connect the chamber's electrical source plug(s) to the appropriate service receptacle(s). The use of extension cords and/or power strips is strictly prohibited.

⚠ CAUTION

Insufficient electrical service will cause the circuit breaker to trip at the service load center, leading to premature failure and voiding the warranty.



Single 20-amp duplex circuit rated for only one power cord.



Two cords plugged into the same circuit is not recommended.



Quadplex 20-amp outlet. Each side should be labeled if separate circuits. Left side on one circuit (one cord), right side on another circuit for the second cord.

Be sure that all plugs are secured before switching the power on.

After ensuring that all the plugs are secure, turn the power switch located on the control panel to the "On" position. If the chamber does not immediately power up, a malfunction in the unit may have occurred. If this happens, please contact Percival Scientific as soon as possible to request technical assistance.

Chamber Operating Ranges

⚠ CAUTION

Operating the chamber outside the ranges listed could result in mechanical failure of the chamber.

Temperature

The Series 41 chamber was designed to operate within the temperature ranges specified in Table 1.

Table 1 Chamber Operating Ranges (Temperature)	
GR-41VL	5°C to 44°C ± 0.5°C (lights on) * 2°C to 44°C ± 0.5°C (lights off) *
AL-41L4, AR-41L, E-41L, E-41HO, LED-41L1	7°C to 44°C ± 0.5°C (lights on) * 2°C to 44°C ± 0.5°C (lights off) *
CU-41L4, CU-41L5, GR-41L, LED-41L2	10°C to 44°C ± 0.5°C (lights on) * 2°C to 44°C ± 0.5°C (lights off) *
LT-41	-10°C to 44°C ± 0.5°C (lights on) * -15°C to 44°C ± 0.5°C (lights off) *

* - These temperatures are achievable when ambient conditions are 24°C (75°F) or below. Higher ambient temperatures may affect the operating ranges.

Humidity (if applicable)

The Series 41 chamber was designed to operate within the humidity ranges specified in Table 2.

Table 2 Chamber Operating Ranges (Humidity) over 15° to 30°C				
RH Sensor	Humidification only	Dehumidification only	Humidification w/ Dehumidification	Tolerance
HMP60 (0-1V)	Up to 85% *	Down to 40% *	40% to 85% *	±10%
HMP110 (0-5V)	Up to 85% *	Down to 40% *	40% to 85% *	±5%

* - These humidity levels are obtainable with all lights off. With the lights turned on, the maximum humidity level that can be obtained will decrease.

Note: The operating temperature range for all standard humidification / dehumidification packages is **15°C to 30°C**. Chambers equipped with any standard humidification / dehumidification option must be operated within this specified temperature range when the humidification / dehumidification system is enabled. If test requirements call for temperatures below 15°C or above 30°C, the humidification / dehumidification system should be disabled. Please refer to the attached *IntellusUltra Controller Manual* for instructions regarding disabling the humidification / dehumidification systems. Also, if the chamber is to be operated at temperatures near freezing, the humidifier should be drained, and the water line shut off valve should be closed. Failure to follow these procedures could result in loss of temperature control or cause mechanical malfunction in the chamber.

Control System

The control system of the chamber consists of an IntellusUltra microprocessor programmable controller and the mechanical components that condition the chamber environment. Please refer to the attached *IntellusUltra Controller Manual* provided for information on using the microprocessor to program chamber temperature, humidity (if provided), CO₂/Auxiliary (if provided) and lighting (if provided).

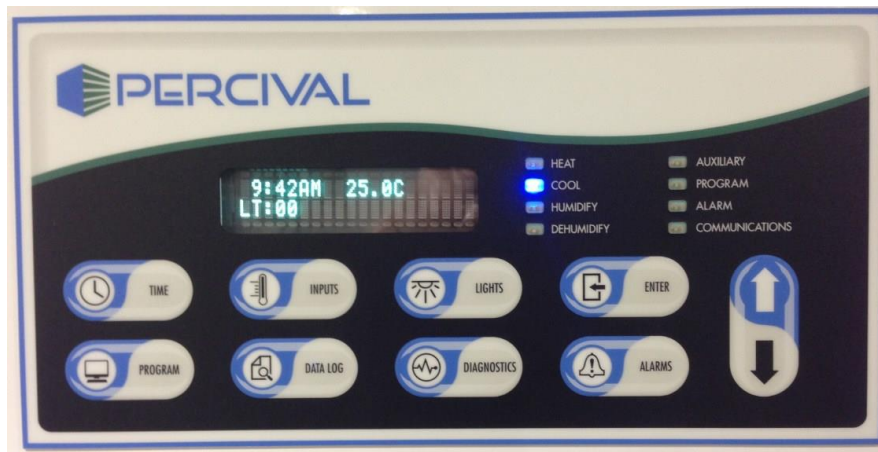

IntellusUltra Controller

On standard 41 series chambers, a ceiling mounted unit cooler, employing air circulating fans and an evaporator, works in conjunction with one or more electric heaters and a condensing unit to heat and cool the chamber. Heating of the air is accomplished using electrical wire heaters and by diverting hot gas from the compressor to the evaporator. Cooling of the air is accomplished by diverting refrigerant to the evaporator.

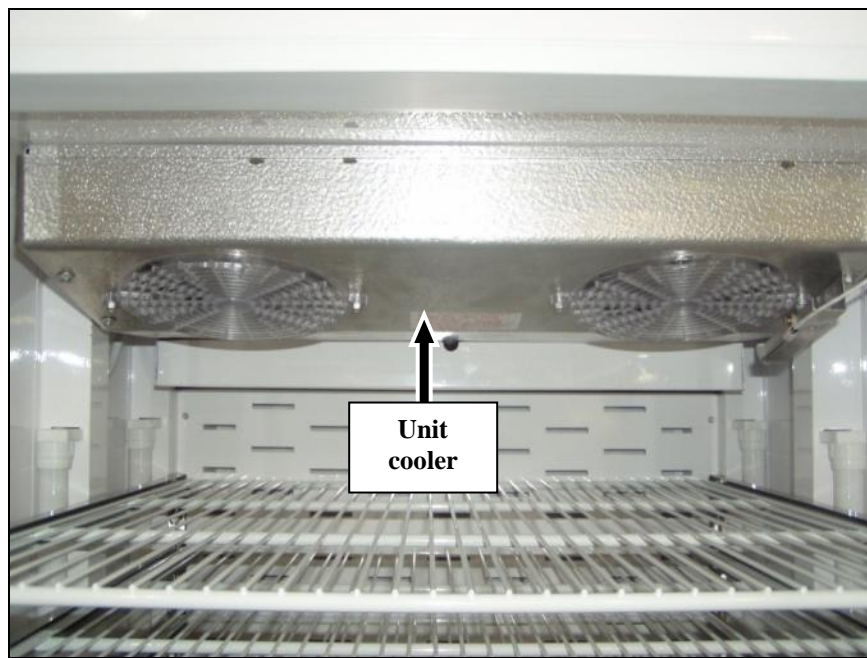

Note: When placing your experiment on the shelving, locate the containers in as uniform and evenly spaced pattern as possible to minimize the obstruction of developed airflow patterns.

LT-41 Defrost System

LT-41 models are designed for low temperature applications and can achieve temperatures down to -12°C . Typically, low temperature systems from Percival Scientific are defrosted by the diversion of hot gas through a single unit cooler, but this causes a significant temperature spike during the defrost period. To reduce the temperature spike that occurs, a dual unit cooler system has been utilized. As one unit cooler is cooling, the other unit cooler is defrosted via hot gas.

Each unit cooler spends half of its time in cooling and half of its time being defrosted. **Note!** The cycle time of the unit coolers is programmed during manufacturing at the factory.

If you notice ice build-up on the active unit cooler it may be necessary to change the frequency of intervals between the switching cycles of the unit coolers. **Please contact the Percival factory for assistance.**

Heating elements within the side wall windows, door and door frame automatically energize at low temperatures to prevent condensate build-up. A drain heater also automatically energizes at low temperatures to prevent the drain line from freezing. **Note!** When servicing the unit, these heaters should not be allowed to run with the unit cooler fans off for an extended period.

During low temperature operation, the floor drain plug should be installed to prevent ambient air from affecting the chamber temperature control. During normal temperature operation the plug should be removed.



Important! If so equipped, the access port stoppers must be installed and the door fresh air ports should be closed when running temperatures near and below freezing.

Please contact Percival Scientific, Inc. with any specific questions regarding this system.

Remote Alarm Contacts (if applicable)

If the remote alarm option is incorporated, a terminal block is provided to connect an existing remote alarm system to the chamber's temperature limit system. Dry alarm contacts are provided with a normally closed set of contacts and a normally open set of contacts.

Depending on the input trigger required for the existing alarm system, make an electrical connection from the alarm input to the appropriate terminals on the terminal block. If a temperature limit occurs, the state at each set of the contacts will change, meaning that the normally open contacts will close, and the normally closed contacts will open.

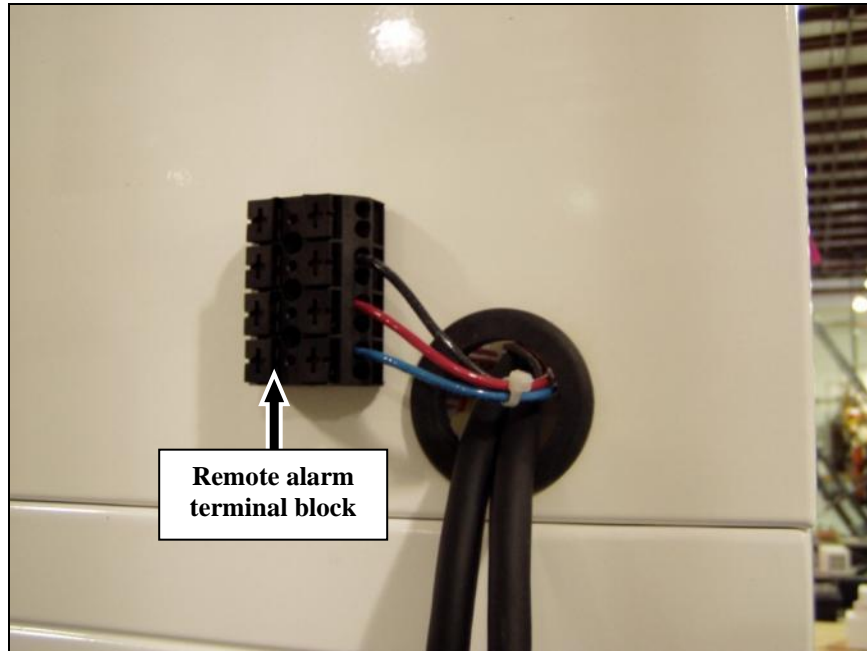

Air Blocks (if applicable)

Air blocks may have been provided to increase or decrease the level of airflow over one or more shelves. If you desire more or less airflow over a shelf, adjust an air block by loosening the screws for the air block you wish to adjust. Each air block is adjusted with a pair of screws. **Do not remove the screws or the air block panel will detach.** Only unscrew the screws far enough so that the air block panel will slide horizontally. Once the panel has been adjusted, retighten the screws.

Percival Scientific adjusts the panels at the factory to achieve optimum temperature uniformity between each tier of shelving. Normally, you do not need to adjust the panels. If you observe that the temperature uniformity is not optimal, you can adjust the panels. Please be aware that adjusting the panels will affect the uniformity over the other tiers of shelving (e.g. increasing the airflow over the top tier of shelving will decrease the airflow over the lower tiers).

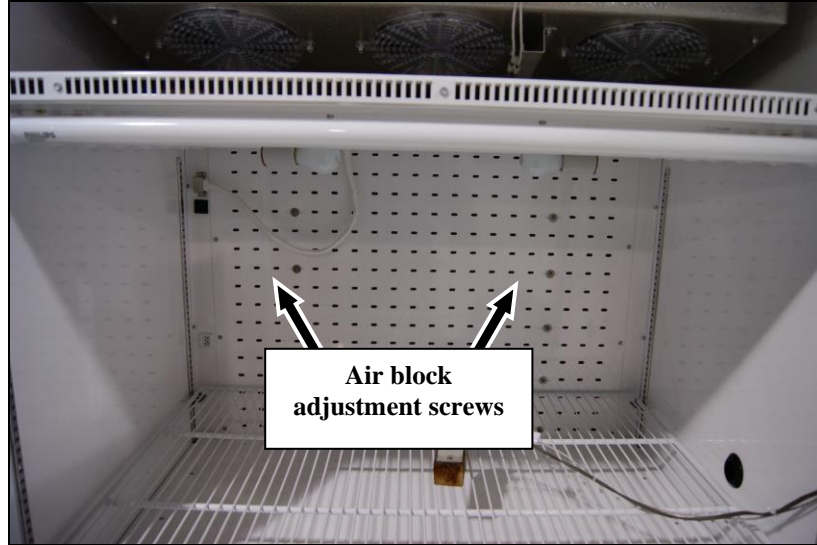

Chamber Lighting

The IntellusUltra controller is used to control all lighting within the chamber. Please refer to the attached *IntellusUltra Controller Manual* provided for more information. LED lighting is accomplished in a dimmable fashion. Fluorescent lighting (if equipped) is accomplished in either an on/off or dimmable fashion. If the lighting is controlled in an on/off fashion, one or more lighting outputs have been set up on the IntellusUltra controller to turn the lights on and off.

If the lighting is controlled in a dimmable fashion, either the auxiliary channel or one or more lighting outputs have been set up on the IntellusUltra controller to dim the lights. If the fluorescent lights are set up to dim, there will be a minimum and maximum programmable level allowed for the lighting. Please refer to the supplemental information on dimmable lighting provided in the *Associated Diagrams, Schematics, and Miscellaneous Information* section for additional information.

Lighting Specifications

Table 3 Lighting specifications in micromoles (μmoles)	
AR-41L, AR-41L3	405 $\mu\text{moles} / \text{m}^2 / \text{sec} *$
AL-41L	405 $\mu\text{moles} / \text{m}^2 / \text{sec} *$
CU-41L4, CU-41L5	405 $\mu\text{moles} / \text{m}^2 / \text{sec} *$
E-41L	800 $\mu\text{moles} / \text{m}^2 / \text{sec} *$
E-41HO	1600 $\mu\text{moles} / \text{m}^2 / \text{sec} *$

GR-41L	75 $\mu\text{moles} / \text{m}^2 / \text{sec} *$
GR-41VL	50 $\mu\text{moles} / \text{m}^2 / \text{sec} *$
E-41VL, LT-41	515 $\mu\text{moles} / \text{m}^2 / \text{sec} *$
LED-41L1	1850 $\mu\text{moles} / \text{m}^2 / \text{sec} *$
LED-41L2	1550 $\mu\text{moles} / \text{m}^2 / \text{sec} *$

* - All published light intensities are measured 6" from the lamps at a temperature of 24°C and a lamp lifetime of 100 hours. These conditions for measurement are a plant growth industry standard.

Chamber Humidity (if applicable)

The IntellusUltra controller is used to control any humidification or dehumidification system provided with the chamber. Please refer to the attached *IntellusUltra Controller Manual* provided for more information.

When the controller senses the chamber relative humidity level has dropped below the set point, it activates the humidification system if it is programmed to be on. When the controller senses that the relative humidity level has risen above the set point, it activates the dehumidification equipment (if applicable) if the dehumidification system is programmed to be on. When relative humidity levels considerably above ambient are desired, turn the dehumidification system off. Likewise, for low relative humidity levels deactivate the humidification system. Depending on ambient conditions, relative uniformity should improve.

The performance of humidity control is dependent upon the laws of thermodynamics. The temperature controller cycles the flow of refrigerant to the evaporator coils and the relative humidity will fluctuate as the temperature of the evaporator coils fluctuate.

Excessive dehumidification will cause the dehumidifying coil (if applicable) to freeze water on its surface, thus reducing the air flow, which in return will cause poor temperature and humidity control. If this condition occurs, raise the relative humidity control setting.

Note: The operating temperature range for all standard humidification / dehumidification packages is **15°C to 30°C**. Chambers equipped with any standard humidification / dehumidification option must be operated within this specified temperature range when the humidification / dehumidification system is enabled. If test requirements call for temperatures below 15°C or above 30°C, the humidification / dehumidification system should be disabled. Please refer to the attached *IntellusUltra Controller Manual* for instructions regarding disabling the humidification / dehumidification systems. Also, if the chamber is to be operated at temperatures near freezing, the humidifier should be drained, and

the water line shut off valve should be closed. Failure to follow these procedures could result in loss of temperature control or cause mechanical malfunction in the chamber.

Maintenance

The following information describes the recommended maintenance procedures that should be periodically performed.

⚠ WARNING

Insure that chamber power is removed prior to performing any maintenance!

Condensate pan (if applicable)

If provided, the condensate pan is located under the chamber. This pan collects all water drained from the chamber and should be checked weekly and emptied as required. You do not need to shut off power to the chamber when emptying the condensate pan.

Recommended maintenance schedule: Weekly.

Case

To clean the chamber's interior and exterior, use soap (or mild liquid detergent) and water. Do not use abrasive type cleaners because these will scratch the surface.

To clean stainless steel, use an approved stainless steel cleaner.

Recommended maintenance schedule: Every 3 months.

Air cooled condensing unit (if applicable)

It is necessary for air to pass freely over the condenser. Air flow is provided by a fan and motor which operate when the chamber is on. Dust will tend to collect on the condenser and condenser fan blade on the side at the point of air entry. To clean, locate the condenser and fan blade on the condensing unit. Blow the dust out of the condenser from behind with compressed air or by brushing and vacuuming. Wipe the condenser fan blade with a clean cloth to remove dust and dirt.

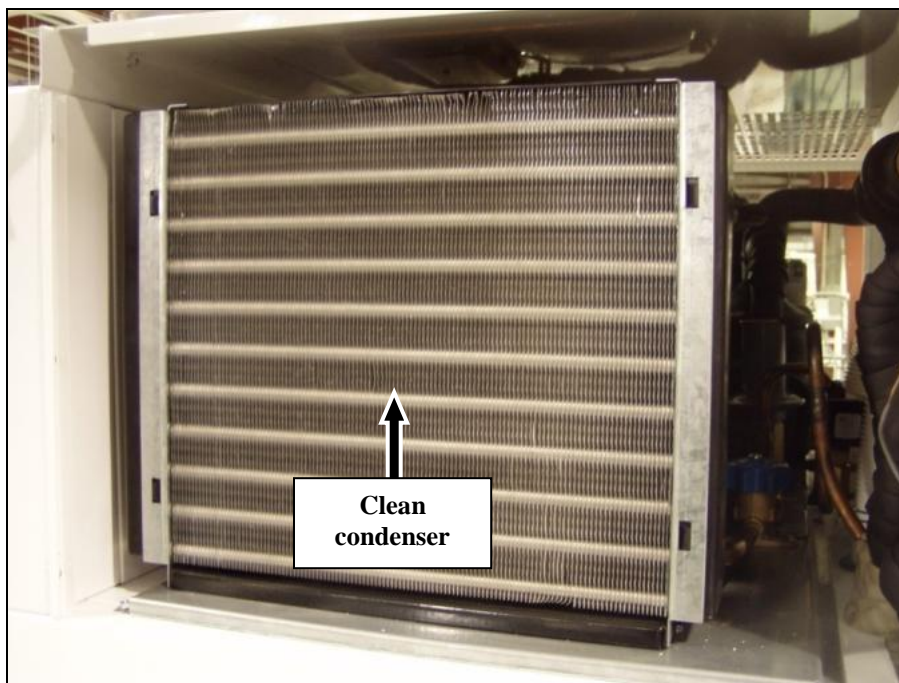
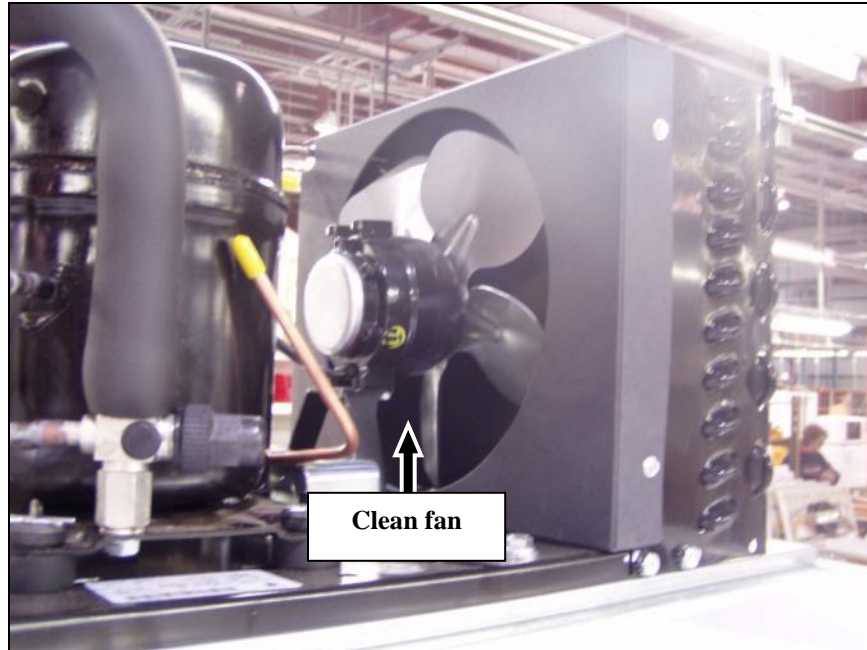

Recommended maintenance schedule: Every 3 months.

Water cooled condensing unit (if applicable)

It is recommended that a service group check the condensing unit's water flow rate every six to twelve months.

Evaporator and fan blades (unit cooler)

It is recommended that the evaporator and fan blades be inspected for the accumulation of dirt. To access the evaporator and blades, remove the upper light fixtures as necessary and carefully remove the unit cooler cover. Accumulation of dirt around the evaporator fin openings will indicate the need for cleaning the blades and evaporator. Clean the evaporator by brushing, vacuuming and/or by using compressed air. The unit cooler drain line and drip pan should be checked and cleaned at this time with a solution of vinegar and water.

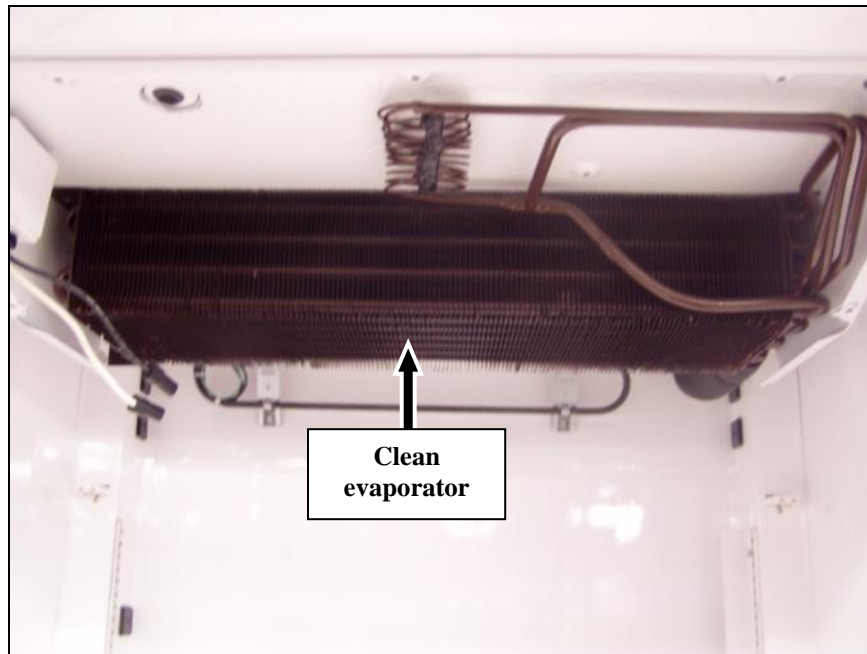

On chambers provided with phenolic coated evaporator coils, the following procedures can be used to clean the evaporator.

Note: The following procedures are approved for **phenolic coated coils only** and should not be used for chambers equipped with standard coils.

1. Disconnect power to the chamber by removing all chamber power cords.
2. Remove all interior lamp fixtures and shelving. There may be electrical heaters mounted behind the unit cooler that should be removed prior to cleaning.
3. Flush the coil with water to rinse loose residue clean and allow the water to soak 10-20 minutes to loosen any surface residue. Avoid spraying water into any exposed receptacles.
4. Acceptable cleaners
 - a. Liquid soap detergent and warm water
 - b. Lysol
 - c. Pinesol

- d. Pine oil or other terpene-based cleaners
5. Flush unit with cleaner thoroughly until all signs of residue are eliminated.
6. Rinse with clean water.
7. Allow the unit to dry completely prior to putting the unit back into service.

Recommended maintenance schedule: Every 12 months.

Air diverters (CU-41 model only)

To clean the air diverters, remove the shipping screws and carefully slide the diverter out of the chamber. Remove the perforated cover by removing the screws. Clean the inside of the diverter. After cleaning, re-install the perforated cover and carefully slide the diverter back into the chamber. Ensure the diverter is pushed all the way against the rear wall.

Repeat this process with any additional diverters.

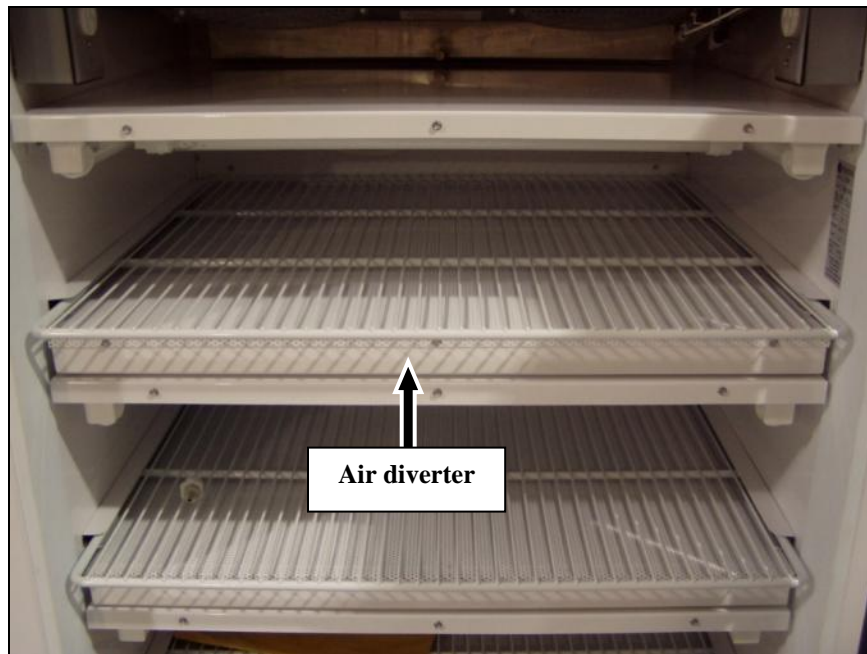

SciWhite® LED tiles

The SciWhite® LED tiles are designed for maintenance-free operation. It is recommended that the light intensity level is checked after 50,000 hours of use. This can be accomplished using an independent light meter.

Should you have concerns or any issues with LED tiles prior to that time, **please contact the Percival factory for assistance.** We can be reached via telephone by calling either 1-800-695-2743 or 515-465-9363, or by sending e-mail to service@percival-scientific.com.

Fluorescent lamps (If equipped on AL-41, AR-41, CU-41, E-41, GR-41 models)

The style of lamps used in this chamber may not show visible signs of aging (darkening of the ends). Due to the decreased light intensity as a result of aging bulbs it is recommended that the lamps in this chamber be replaced after every 15,000 hours of use. The lamps may need to be replaced more frequently depending on experiment conditions. **Failure to replace lamps may cause damage to lamp fixtures.**

Refer to the chamber lighting diagram(s) provided in the *Associated Diagrams, Schematics and Miscellaneous Information* section of this manual for lamp style and wattage requirements.

To remove a lamp, grasp the ends of the lamp by the lamp holder caps and pull the lamp straight away from the lamp holders. To install a lamp, place lamp end caps (supplied) on each end of a lamp and slide the lamp with caps over the lamp holders until it snaps into place *. Do not twist the lamps or they may break. Repeat this process with any additional lamps.

*** - Note: The lamp holder caps must be securely installed against the lamp holders! Please reference the drawings below:**

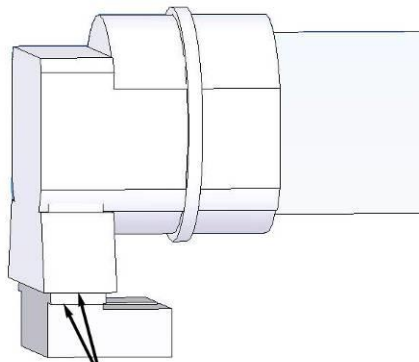

See Caption
Incorrect installation – gap exists between lamp holder cap and lamp holder

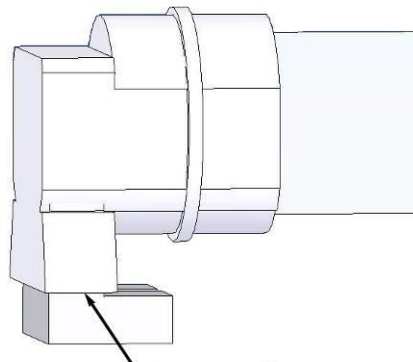

See Caption
Correct installation – no gap exists

Note: Never plug in lights or light fixtures unless the chamber power is off.

Note: The chamber utilizes multiple-lamp ballasts. When changing bulbs, it is recommended that all lamps controlled by a multiple-lamp ballast are simultaneously replaced. Typically, a single ballast controls four lamps in the following models: AR-41L, CU-41L, E-41L, LT-41VL. Typically, a single ballast controls two lamps in the following models: GR-41L, GR-41VL. Typically, a single ballast controls three lamps in the following models: AL-41L.

Recommended maintenance schedule: Every 12 months.

Compact fluorescent lamps (If equipped on E-41HO)

Due to the decreased light intensity because of aging bulbs it is recommended that the lamps in this chamber be replaced after every 10,000 hours of use. The lamps may need to be replaced more frequently depending on experiment conditions. **Failure to replace lamps may cause damage to lamp fixtures.**

Refer to the chamber lighting diagram(s) provided in the *Associated Diagrams, Schematics and Miscellaneous Information* section of this manual for lamp style and wattage requirements.

To remove a compact fluorescent bulb when metal support clips are supplied, pull downward on the bulb near the clip and once the bulb is free from the support clip, pull bulb straight away from lamp holder. To install a compact fluorescent bulb, insert the bulb into the lamp holder and push upward on the opposite end of the bulb near the clip until the clip supports the bulb.

To remove a compact fluorescent bulb when plastic support clips are supplied, unclip the end support and pull bulb directly away from lamp holder. To install a compact fluorescent bulb, insert the bulb into the end support clip and then push lamp directly into the lamp holder. Next, secure the lamp by closing the clip.

Note: The chamber utilizes multiple-lamp ballasts. When changing bulbs, it is recommended that all lamps controlled by a multiple-lamp ballast are simultaneously replaced. Typically, a single ballast controls two lamps in the E-41HO model.

Pan type humidifier (if applicable)

If provided with a humidifier pan that is mounted behind the unit cooler it is recommended that the pan be removed and cleaned. Prior to cleaning the pan, shut off the water supply to the humidifier by closing the water supply hand valve located on the outside side or rear wall of the chamber. Remove the upper light fixture and shelf. Place a bucket under the drain tubing located in the pan front. Open the drain and allow all water to drain from the pan. On CU-41 models it may be necessary to remove more than one fixture and shelf in order to fit a bucket under the drain tube. Remove the top rear false wall cover by removing the screws that secure the cover to the receptacle panels. Detach the drain tube from the humidifier pan. Next, unplug the humidifier heater and float switch power cords from their receptacles. Remove the humidifier pan by unscrewing the pan from the rear receptacle panels and ceiling. Remove the humidifier heater and float switch from the pan. Clean the pan with a mixture of vinegar and water. Baking soda may also be added to the mixture if necessary. When finished, reinstall the components in the reverse order.

If provided with a humidifier pan located on the floor of the chamber it is recommended that the pan be removed and cleaned. Prior to cleaning the pan, shut off the water supply to the humidifier by closing the water supply hand valve located on the outside right-hand or rear wall of the chamber. To remove the pan, unplug the humidifier heater

power cord from its receptacle. Next, disconnect the water line connection from the pan. The pan should now be able to be removed from the chamber. Remove the humidifier heater and float from the pan. Clean the pan with a mixture of vinegar and water. Baking soda may also be added to the mixture if necessary. When finished, reinstall the components in the reverse order.

Recommended maintenance schedule: Every 6 months or sooner depending on water quality.

LT-41 and E-41VL lamp ballasts (if applicable)

For LT-41 and E-41VL models equipped with fluorescent lighting, if it becomes necessary to service the ballasts, they are accessed by opening the lamp fixture and removing the screws in the lamp holder base. Refer to the photo below for screw locations. Once the screws have been removed, the lamp holder base can swing open as it is installed on hinges. The ballasts are mounted to the lamp holder base.

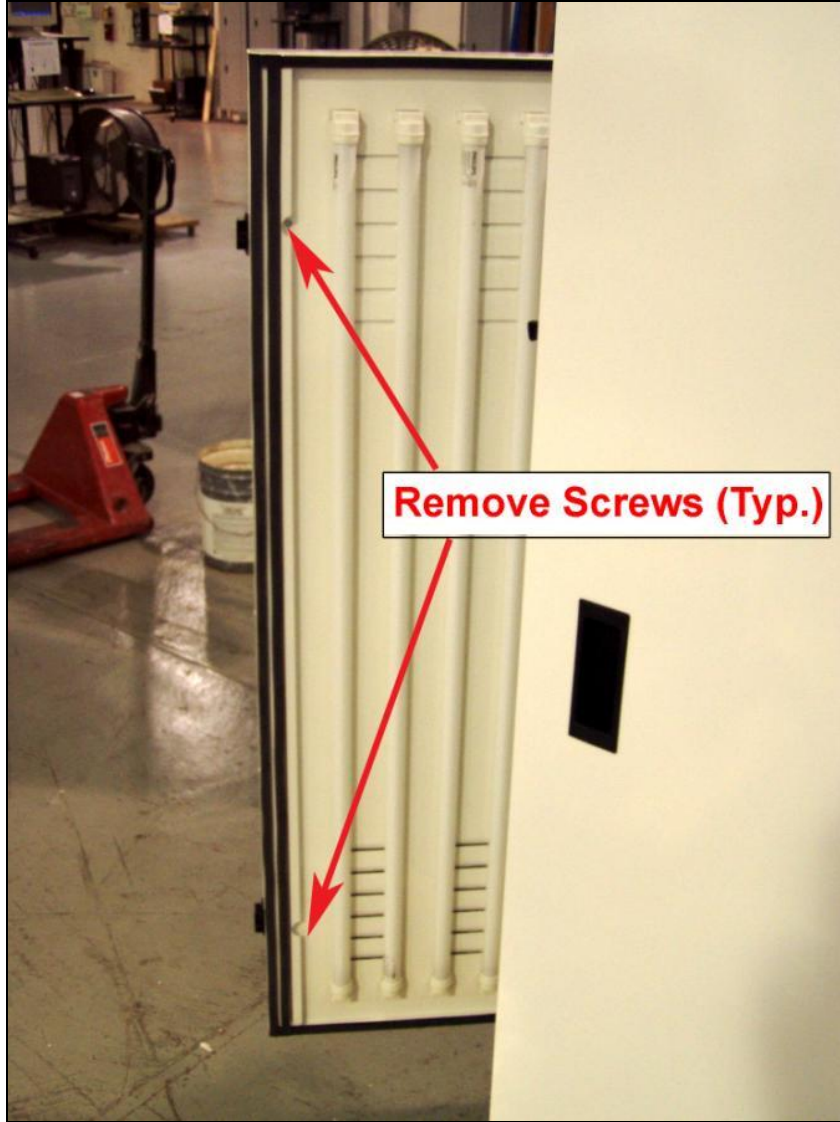

Temperature Conversion Chart

Locate the temperature you wish to convert in the center or common column of the chart. If you are converting a Centigrade reading to Fahrenheit, read the adjacent Fahrenheit temperature in the right hand column under F. For a Fahrenheit conversion to Centigrade, read the adjacent Centigrade temperature in the left-hand column under C.

C.	F.	C.	F.	C.	F.	C.	F.	
-73.3	-100	-148	0.56	33	91.4	24.4	76	168.8
-67.8	-90	-130	1.11	34	93.2	25.0	77	170.6
-62.2	-80	-112	1.67	35	95.0	25.6	78	172.4
-56.7	-70	-94	2.22	36	96.8	26.1	79	174.2
-51.1	-60	-76	2.78	37	98.6	26.7	80	176.0
-45.6	-50	-58	3.33	38	100.4	27.2	81	177.8
-40.0	-40	-40	3.89	39	102.2	27.8	82	179.6
-34.4	-30	-22	4.44	40	104.0	28.3	83	181.4
-28.9	-20	-4	5.00	41	105.8	28.9	84	183.2
-23.3	-10	-14	5.56	42	107.6	29.4	85	185.0
-17.8	0	32	6.11	43	109.4	30.0	86	186.8
-17.2	1	33.8	6.67	44	111.2	30.6	87	188.6
-16.7	2	35.6	7.22	45	113.0	31.1	88	190.4
-16.1	3	37.4	7.78	46	114.8	31.7	89	192.2
-15.6	4	39.2	8.33	47	116.6	32.2	90	194.0
-15.0	5	41.0	8.89	48	118.4	32.8	91	195.8
-14.4	6	42.8	9.44	49	120.2	33.3	92	197.6
-13.9	7	44.6	10.0	50	122.0	33.9	93	199.4
-13.3	8	46.4	10.6	51	123.8	34.4	94	201.2
-12.8	9	48.2	11.1	52	125.6	35.0	95	203.0
-12.2	10	50.0	11.7	53	127.4	35.6	96	204.8
-11.7	11	51.8	12.2	54	129.2	36.1	97	206.6
-11.1	12	53.6	12.8	55	131.0	36.7	98	208.4
-10.6	13	55.4	13.3	56	132.8	37.2	99	210.2
-10.0	14	57.2	13.9	57	134.6	37.8	100	212.0
-9.44	15	59.0	14.4	58	136.4	38	100	212.0
-8.89	16	60.8	15.0	59	138.2	43	110	230.0
-8.33	17	62.6	15.6	60	140.0	49	120	248.0
-7.78	18	64.4	16.1	61	141.8	54	130	266.0
-7.22	19	66.2	16.7	62	143.6	60	140	284.0
-6.67	20	68.0	17.2	63	145.4	66	150	302.0
-6.11	21	69.8	17.8	64	147.2	71	160	320.0
-5.56	22	71.6	18.3	65	149.0	77	170	338.0
-5.00	23	73.4	18.9	66	150.8	82	180	356.0
-4.44	24	75.2	19.4	67	152.6	88	190	374.0
-3.89	25	77.0	20.0	68	154.4	93	200	392.0
-3.33	26	78.8	20.6	69	156.2	99	210	410.0
-2.78	27	80.6	21.1	70	158.0	100	212	413.0
-2.22	28	82.4	21.7	71	159.8	104	220	428.0
-1.67	29	84.2	22.2	72	161.6	110	230	446.0
-1.11	30	86.0	22.8	73	163.4	116	240	464.0
-0.56	31	87.8	23.3	74	165.2	121	250	482.0
0.00	32	89.6	23.9	75	167.0			

Service Information - Temperature System

WARNING

**Disconnect all unnecessary electrical power when servicing equipment.
Majority of circuits are high voltage.**

Loss of temperature control - overheating or overcooling

- ✓ **IntellusUltra controller:** Check the controller for the correct voltage output to the heating and/or cooling relay. The voltage should be approximately 5VDC. If the controller fails to output the correct voltage, repair or replace the controller.
- ✓ **Temperature sensor:** Check the sensor for the correct resistance and replace if necessary. The correct resistance is 100 ohms at 0°C.
- ✓ **Heating and/or cooling relays (as applicable):** Check the existing heating and/or cooling relays for correct output voltage.
- ✓ **Hot gas solenoid valve:** When in the heating mode, the hot gas solenoid valve should be open and in the cooling mode the valve should be closed. If the valve is not functioning, replace solenoid or entire valve, evacuate, and recharge the refrigeration system - see Refrigeration Diagram and/or serial tag for type and amount of charge.
- ✓ **Liquid line solenoid valve:** When in the heating mode, the liquid line solenoid valve should be closed and in the cooling mode the valve should be open. If the valve is not functioning, replace solenoid or entire valve, evacuate, and recharge refrigeration system - see Refrigeration Diagram and/or serial tag for type and amount of charge.

Loss of temperature control - overheating

- ✓ **Loss of refrigerant:** Check for loss of refrigerant. If leaks are found, correct, evacuate and recharge the refrigeration system - see Refrigeration Diagram and/or serial tag for refrigerant type and amount.
- ✓ **Restricted expansion device or restricted drier:** If adequate refrigerant exists in the system and if suction pressures are acceptable, the expansion device (capillary tube or expansion valve) inlet and/or the drier could possibly be restricted. To check the drier, gauge the outlet temperature with the inlet temperature. If the outlet is as warm as the inlet temperature, the drier is operating properly - if colder than the inlet, the drier is restricted.
- ✓ **Condenser & condenser fan (if applicable):** Check the condenser and fan. If dirty, clean condenser and fan. Replace motor and fan if necessary. Check condenser air inlet temperature near center from approximately one inch away. If above 90°F, provide cooler air (by means of a circulation fan, air conditioner, etc.). If water-cooled, check the head

pressure and rate of flow. If necessary, adjust the rate of flow, clean condenser, or replace condenser.

- ✓ **Compressor:** If the compressor fails to operate, check the power source, overload protector, start relay (if provided), and windings. Replace as required.
- ✓ **Air circulating fans:** If the chamber is overheating, check the air circulating fans. Clean as necessary. If the fans are not operating properly, replace either the motor or the entire assembly (fan, motor, and blade).
- ✓ **Evaporator:** Check evaporator airflow openings by observing the amount of light passing through the fin spaces. Clean as required.

Loss of temperature control - overcooling

- ✓ **Heating heater:** Check the heating heater located inside the chamber for proper function.
- ✓ **Reheat heater (if applicable):** If the chamber overcools when in the dehumidification mode, check the reheat heater for proper function.

General temperature system problems

- ✓ **Temperature indicator reads incorrect temperature:** If the temperature inside the chamber disagrees with the indicator, adjust the calibration offset.

Service Information – Fluorescent Lighting (if applicable)

⚠ WARNING

**Disconnect all unnecessary electrical power when servicing equipment.
Majority of circuits are high voltage.**

Lighting malfunctions - group of lamps not on

- ✓ **IntellusUltra controller:** Check the controller for correct voltage output to the lighting relays. The voltage should be approximately 5VDC. If the controller fails to output the correct voltage, the controller will need to be repaired or replaced.
- ✓ **Lighting relay:** Check existing lighting relays for proper function and replace if necessary.

Lighting malfunctions - fluorescent not on

- ✓ **Installation:** Check to ensure that lamp is installed properly in lamp holder. For standard tube fluorescent lamps, if the distance between the lamp holders is too great, loosen the retaining screws and move the holders closer to the center of the lamp. Check lamp wiring and connections.
- ✓ **Lamp failure:** Replace the defective lamp with a known good lamp and, if necessary, replace defective lamp. Replace other lamps controlled by the defective lamp's ballast. See note under lamp maintenance about changing all lamps powered by a multi-lamp ballast.
- ✓ **Ballast failure:** Locate the defective ballast by tracing wires to lamps that are not functioning properly.

Service Information - Humidity System (if applicable)

⚠ WARNING

**Disconnect all unnecessary electrical power when servicing equipment.
Majority of circuits are high voltage.**

Loss of humidity control

- ✓ **IntellusUltra controller:** Check the controller for correct voltage output to the humidification and/or dehumidification relay. If the controller fails to output the correct voltage (approximately 5VDC), repair or replace the controller.
- ✓ **Signal conditioner and/or sensor failure:** If provided, check the voltage signal from the signal conditioner to the controller. For the HMP60 sensor, the voltage should be more than 0VDC but less than 1VDC. For the HMP110 sensor, the voltage should be more than 0VDC but less than 5VDC. If it is not, the sensor may need to be replaced.
- ✓ **Humidification and/or dehumidification relays:** Check humidification and/or dehumidification relays for the correct output voltage.

Loss of humidity control - over dehumidifies

- ✓ **Dehumidification solenoid valve (if applicable):** If the valve will not close, replace the solenoid or entire valve, evacuate, and recharge the refrigeration system - see refrigeration diagram and/or serial tag for type and amount of charge.

Loss of humidity control - no humidification

- ✓ **Insufficient water level in humidifier:** Check the water in the humidifier and, if low, check for proper operation of the mechanism that fills the humidifier (float valve, solenoid valve, etc.).

- ✓ **Humidification heater(s) failure:** Check humidification heater(s) for proper operation.

Loss of humidity control - no dehumidification

- ✓ **Dehumidification solenoid valve (if applicable):** If valve will not open, replace solenoid or entire valve, evacuate, and recharge the refrigeration system - see refrigeration diagram and/or serial tag for type and amount of charge.
- ✓ **Refrigeration system failure:** Check other components of refrigeration system for proper operation.

Service Information - General

⚠ WARNING

**Disconnect all unnecessary electrical power when servicing equipment.
Majority of circuits are high voltage.**

- ✓ **Chamber does not power up:** Check source (facility) electrical power, circuit breakers, fuses, etc. Check chamber power cords, circuit breakers, power switches, etc.
- ✓ **Convenience receptacles do not work:** Check wiring, connections, and physical condition of receptacles.
- ✓ **Circuit breaker trips:** Check electrical system for shorts and convenience receptacles for overloading. Check voltage to chamber. Check electrical connections (must be tight) at circuit breaker.

Partial Parts List

Available on request.