

DETAIL D
SCALE 1 : 4



SECTION C-C
SCALE 1 : 8

ITEM NO.	PART NUMBER	DESCRIPTION	QTY.
1	2006-1Q-20-2		1
2	95-3Q-20-3	1/8 X 1 X 1 HRS ANGLE X 28 3/4	2
3	HCS-1	DUAL WHEEL CASTER	4
4	LEVELERS	HLL-001 - SCREW-IN LEVELER	4
5	2006-1Q-20-8	1/8" X 1 1/2" X 1X 1/2" X32 7/8" LONG	1
6	95-3Q-20-6	LEFT HAND SIDE OF FRAME	1
7	95-3Q-20-7	LEFT HAND SIDE OF FRAME	1
8	95-3Q-20C	LEVELER SUPPORT WELD ASS'Y	1
9	Mirror95-3Q-20C		1
10	Mirror95-3Q-20C1		1
11	MirrorMirror95-3Q-20C		1

CUT 3/8" OFF LEVELERS (FOUR REQ'D)

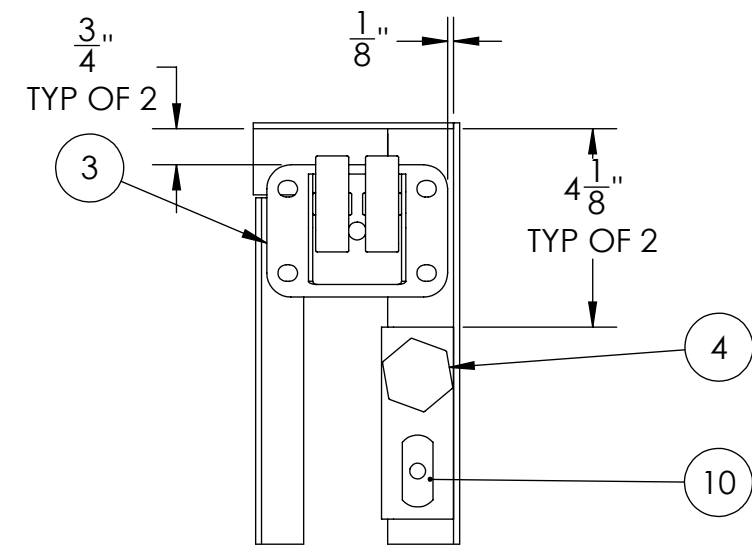
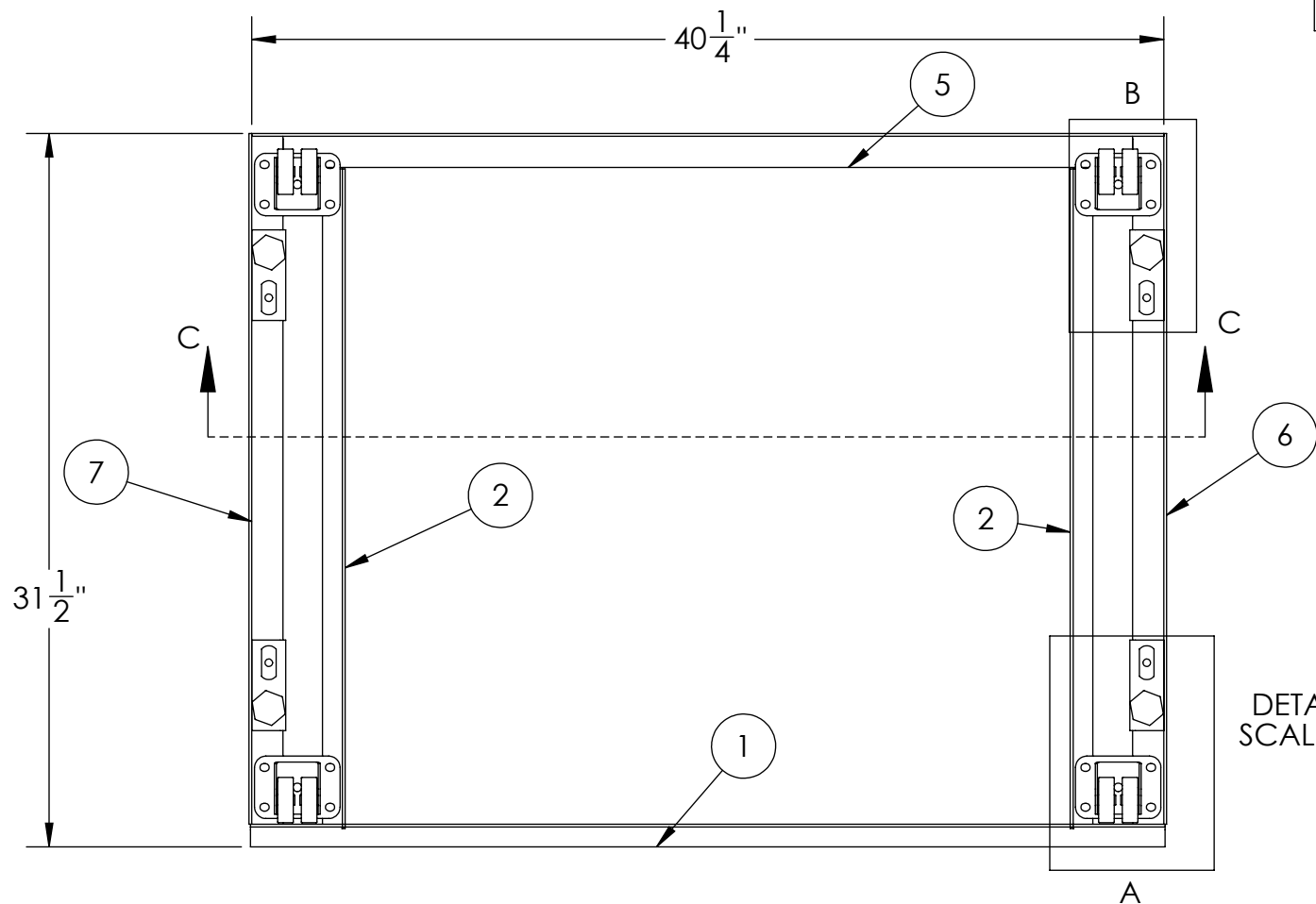

DETAIL B
SCALE 1 : 4

DETAIL A
SCALE 1 : 4

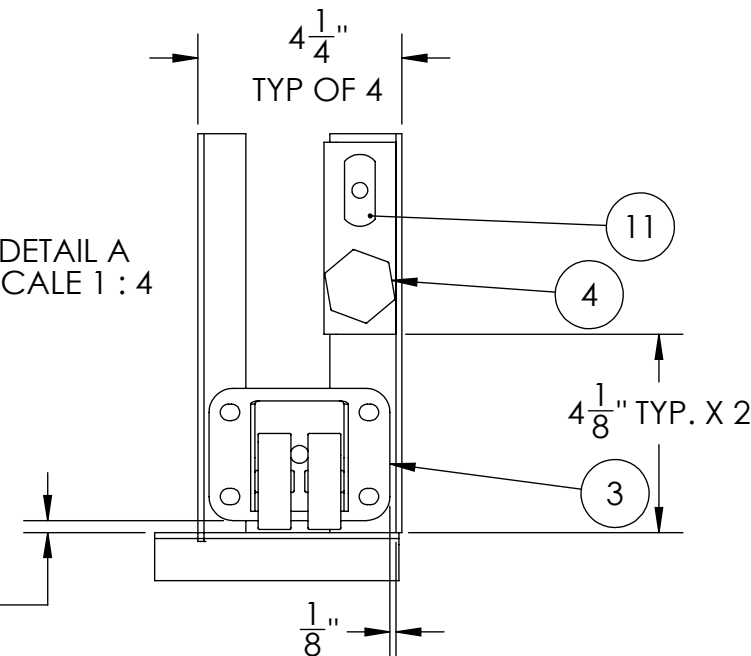

SM OPERATION NOTES

MISC. NOTES

REVISIONS

UNLESS OTHERWISE SPECIFIED:

PROPRIETARY AND CONFIDENTIAL

PERCIVAL SCIENTIFIC, INC.
PERRY, IOWA

1)

REV.	DESCRIPTION	DATE	INITIALS
A		6/23/1998	ENG
B	REMOVED ALL HOLES	2/5/2001	ENG

ALL DIMENSIONS ARE IN INCHES
DRAWING IS NOT TO SCALE
FRACTIONAL TOLERANCE ±1/32"
ANGULAR (BENDS) ±0.5°
DECIMAL VALUES ±0.015

THE INFORMATION CONTAINED IN THIS
DRAWING IS THE SOLE PROPERTY OF
PERCIVAL SCIENTIFIC, INC.. ANY
REPRODUCTION IN PART OR AS A WHOLE
WITHOUT THE WRITTEN PERMISSION OF
PERCIVAL SCIENTIFIC, INC. IS PROHIBITED.

TITLE: BASE ASS'Y		
DRAWING: 2006-1Q-20	REV: D	PART BY: DK
MODEL: 41 SERIES W/ CASTERS		DRAWING BY: RS
DATE APPROVED: 01/21/2026		SHEET 1 OF 1